

TECHNICAL DATA	
O.RING	NBR - EPDM - VITON
SLIPPER	PTFE+CARBON FIBRE
FILTER	700 MICRON
NOZZLES POSITIONS	2 - 4
NOZZLES TYPE	SPECIAL XB 030
MAX OPERATING FLOW	30 L/min
MAX OPERATING PRESSURE	200 bar
MAX OPERATING TEMPERATURE	90 °C
MATERIAL	INOX AISI 304
CONICAL GEARS	FIXED Z=23 ROTATING Z=25
MODULE	1
COMPLETE CYCLE	25 ROTATIONS
COMPLETE CYCLE TIME	1.1 MIN.
ROTATION SPEED	24 RPM
WEIGHT	7.5 KG

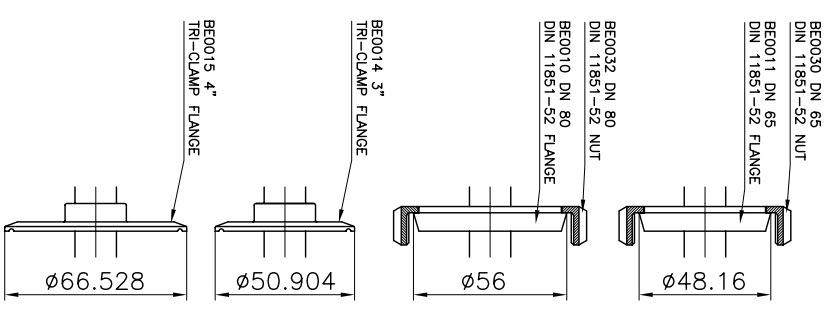

RUPOSITA' (UNI 4800)	MODIFICA	1	2	3	4	5
GREZZO	DATA	XXXX				
TOLLERANZE GENERALI classe m UNI-EN 22768/1						
±0.1	±0.2	±0.3	±0.5	±0.8	±1.2	
NOTE:						
DESCRIZIONE: APPLICATION DRAWING						
XB 031 AAH						
CLEANING HEADS						
MONTECHIO E. (RE) - ITALY						
DISIGN.: CRT CONTR.: DM						
DATA: 18.05.09						
SCALE: 1:3						
CODICE: A4						
MOD.: O						
XB 031 AAH						